

## SECTION J

### THE STEERING GEAR

General description.

Maintenance.

- |                  |   |
|------------------|---|
| Section No. J.1  | Removing and replacing the steering wheel.    |
| Section No. J.2  | Removing the steering column.                 |
| Section No. J.3  | Removing the steering column bushes.          |
| Section No. J.4  | Removing the steering column universal joint. |
| Section No. J.5  | Dismantling the universal joint.              |
| Section No. J.6  | Removing and replacing the steering gearbox.  |
| Section No. J.7  | Dismantling the steering gearbox.             |
| Section No. J.8  | Reassembling the steering gear.               |
| Section No. J.9  | Steering column alignment.                    |
| Section No. J.10 | Checking and adjusting front wheel alignment. |
| Section No. J.11 | Fitting an adjustable steering column.        |
| End of Section   | Special tools.                                |

# THE STEERING GEAR COMPONENTS

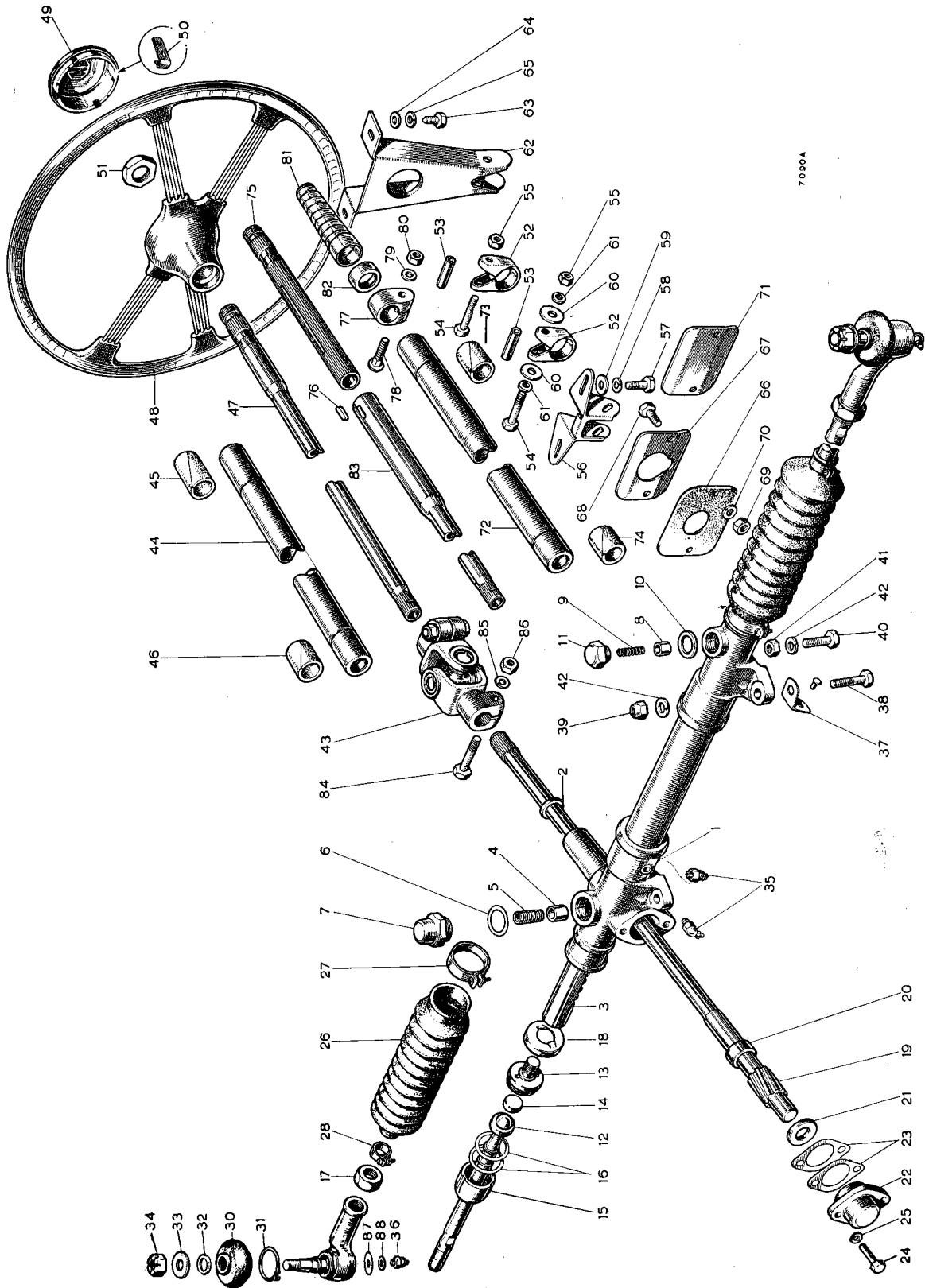

## KEY TO THE STEERING GEAR COMPONENTS

No.	Description	No.	Description	No.	Description
1.	Rack housing assembly (R.H.D.).	31.	Clip for boot.	60.	Plain washer—lower bracket to clamp.
2.	Pinion shaft seal.	32.	Ring for boot clip.	61.	Spring washer—lower bracket to clamp.
3.	Steering rack.	33.	Washer for ball socket.	62.	Steering column bracket (upper).
4.	Rack damper pad.	34.	Nut for ball socket.	63.	Screw—bracket to body rail.
5.	Rack damper spring.	35.	Greaser for pinion/rack.	64.	Plain washer.
6.	Shim for pad housing.	36.	Greaser for ball socket.	65.	Spring washer.
7.	Rack damper housing.	37.	Shim—steering rack to bracket.	66.	Column seal (rubber).
8.	Pad for rack damper secondary.	38.	Bolt—rack to bracket (front).	67.	Retainer for column seal.
9.	Spring for rack damper secondary.	39.	Nut—rack to bracket (nylon).	68.	Screw—seal and retainer to dash.
10.	Washer for rack damper secondary.	40.	Bolt—rack to bracket (rear.)	69.	Nut for seal/retainer screw.
11.	Rack damper secondary housing.	41.	Nut—rack to bracket (rear).	70.	Spring washer for seal/retainer screw.
12.	Tie-rod.	42.	Spring washer—rack to bracket.	71.	Blanking plate.
13.	Male ball housing.	43.	Steering column universal joint.	72.	*Column tube (outer).
14.	Seat for ball.	44.	Tube (outer).	73.	*Bush (upper).
15.	Female ball housing.	45.	Bush—upper end (felt).	74.	*Bush (lower).
16.	Shim for ball housing (.003 in.).	46.	Bush—lower end (felt).	75.	*Top end—adjustable.
17.	Locknut for tie-rod.	47.	Tube assembly (inner).	76.	*Key for top end.
18.	Lock washer for tie-rod.	48.	Steering wheel.	77.	*Collar clamp.
19.	Steering pinion.	49.	Cover for steering wheel.	78.	*Bolt for clamp.
20.	Thrust washer for upper pinion.	50.	Spring clip for cover.	79.	*Spring washer for clamp bolt.
21.	Thrust washer for lower pinion.	51.	Nut for steering wheel.	80.	*Nut for clamp bolt.
22.	Pinion tail bearing.	52.	Steering column clamp.	81.	*Spring cover.
23.	Shim for tail bearing (.005 in.).	53.	Distance piece for clamp.	82.	*Cup for spring cover.
24.	Screw—bearing to steering box.	54.	Bolt for clamp.	83.	*Tube assembly (inner).
25.	Spring washer for bearing screw.	55.	Nut for clamp bolt.	84.	*Bolt for universal joint.
26.	Rack seal.	56.	Steering column bracket (lower).	85.	Spring washer.
27.	Clip assembly for seal (large).	57.	Screw—bracket to frame.	86.	Nut for universal joint bolt.
28.	Clip assembly for seal (small).	58.	Spring washer—bracket to frame.	87.	Washer (steel).
30.	Boot (rubber).	59.	Plain washer—bracket to frame.	88.	Washer (fibre).

\* Optional equipment.

**GENERAL DESCRIPTION**

The steering gear is of the direct-acting rack and pinion type, providing light and accurate control under all conditions.

It consists of a rack bar and toothed pinion, both working in the plain bearings of the housing.

No adjustment for bearing wear in the box is provided, except by the fitting of the necessary new parts.

When in new condition the backlash in the tooth engagement is hardly perceptible, i.e. .001 to .003 in. (.025 to .075 mm.).

The steering mast is attached to the steering gearbox by a universal coupling.

**MAINTENANCE**

All working parts are immersed in oil. An oil gun nipple is provided in the centre of the box to replenish the oil, and a nipple on the pinion housing enables the upper end of the pinion shaft to be lubricated.

Felt bushes are fitted to the steering column. These are impregnated with oil and graphite, and no lubrication should be necessary, but if, after long periods, a dry squeak develops, this may be cured by a small application of oil.

**Section J.1****REMOVING AND REPLACING THE STEERING WHEEL**

Carefully prise the steering wheel cover from the hub of the wheel without chipping the material or the paint-work.

Unscrew the steering wheel nut and mark the wheel hub and column to ensure replacement in the original position. Pull off the wheel with a suitable tool.

When replacing the wheel, position it on the column splines in the original position to place the spokes equally about a horizontal datum line.

Tighten the nut to a torque wrench setting of 500 lb. in. (5.75 kg. m.).

The steering wheel on a car fitted with the optional adjustable steering column may be removed complete with the column extension if necessary.

Remove the clamping nut and bolt from the telescopic adjustment clamp and extend the column as far as possible. Contract the plated helical sleeve and clamp collar towards the steering wheel and extract the key which engages the splined shaft.

Withdraw the steering wheel and column extension.

**Section J.2****REMOVING THE STEERING COLUMN**

Withdraw the clamping bolt and nut securing the universal joint to the steering mast. Remove the nuts and clamp plate to release the draught-excluding rubber from the toeboard at the lower end of the column.

Withdraw the two clamping bolts, nuts, spring and flat washers, and distance tube which support the steering column, and withdraw the column complete with steering mast and steering wheel.

**Section J.3****REMOVING THE STEERING COLUMN BUSHES**

Remove the steering wheel and column assembly as detailed in Section J.2 and withdraw the mast from the outer column. Prise out the felt bushes.

New bushes should be soaked in graphite oil before reassembly.

**Section J.4****REMOVING THE STEERING COLUMN UNIVERSAL JOINT**

Bolts and nuts clamp the universal joint splines on the steering mast and steering pinion, and the bolts must be withdrawn completely to release the universal joint assembly.

Slacken the bolts supporting the steering column below the dash panel.

Withdraw the clamping bolts from the universal joint.

Move the steering column and steering mast assembly upwards to withdraw the steering mast from the universal joint.

Withdraw the universal joint from the steering pinion.

When replacing the universal joint see Section J.9.

**Section J.5****DISMANTLING THE UNIVERSAL JOINT**

The Hardy Spicer joint has four needle-roller bearings retained on a centre spider by circlips. The joints are packed with grease on assembly and there is no further provision for lubrication.

Remove any enamel and dirt from the snap rings and bearing races. Remove the snap rings by pinching the ears together and prising them out with a screwdriver.

If a ring does not slide readily from its groove, tap the end of the bearing race lightly to relieve the pressure against the bearing.

Hold the joint in one hand with the side of a yoke at the top and tap the radius of the yoke lightly with a copper hammer. The bearing should begin to emerge; turn the joint over and remove the bearing and needle rollers with the fingers. If necessary, tap the bearing race from the inside with a small-diameter bar, taking care not to damage the bearing face, or grip the needle-bearing race in a vice and tap the yoke clear.

Repeat this operation for the opposite bearing.

One yoke can now be removed. Rest the two exposed trunnions on wood or lead blocks to protect their ground faces, and tap the top lug of the flange yoke to remove the bearing race.

Turn the yoke over and repeat the operation.

When reassembling, replace the cork gasket and gasket retainers on the spider journals, using a tubular drift. The spider journal shoulders should be shellacked prior to fitting the retainers to ensure a good oil seal.

Smear the walls of the races with grease and assemble the needle rollers to the bearing races and pack with grease.

Insert the spider on one yoke and, using a soft-nosed drift slightly smaller in diameter than the hole in the yoke, tap the bearings into position. It is essential that the bearing races are a light drive fit in the yoke trunnions.

Repeat this operation for the other bearings and replace the circlips, making sure that they are firmly located in their grooves. If the joint appears to bind, tap lightly with a wooden mallet to relieve any pressure by the bearings on the ends of the journals.

## Section J.6

### REMOVING AND REPLACING THE STEERING GEARBOX

**The procedure detailed here will remove the steering rack from a completely assembled car. If the chassis frame front extension has been removed, the steering rack can be removed with the pinion in position.**

Remove the steering rack damper and secondary damper assemblies.

Take out the two bolts and spring washers and withdraw the pinion tail bearing and shims and bottom thrust washer, placing a container to catch any oil that may drain from the steering rack. Support the front end of the car by placing jacks beneath the lower suspension arm spring pans, and remove the road wheels.

Remove the split pins and nuts and drive the tie-rod ball pins from the steering arms. Turn the steering onto the left lock (R.H.D. cars) or right lock (L.H.D. cars). Withdraw the clamping nut and bolt from the universal joint on the pinion shaft and withdraw the pinion

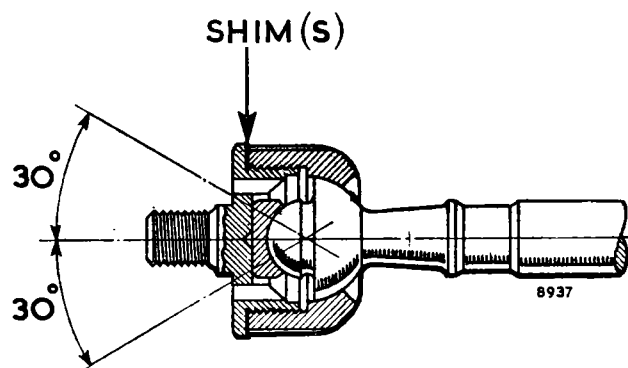

Fig. J.1

*The assembly of a tie-rod ball joint*

assembly. Remove the nuts and bolts securing the steering rack to the chassis frame, noting that the front bolts are fitted with self-locking nuts, and packing shims may be found between the rack and the frame brackets.

Move the steering assembly towards the centre of the car until the steering tie-rod is clear of the front extension plate, and withdraw the assembly downwards.

### Replacing

The steering gearbox is assembled to the car by reversing the above procedure although special attention should be given to the instructions in Section J.9.

When re-engaging the pinion with the universal joint splines, ensure that the cut-away portion for the clamp bolt is aligned with the bolt hole.

## Section J.7

### DISMANTLING THE STEERING GEARBOX

If the steering rack assembly is removed complete with the steering pinion in position, remove the pinion as follows.

Remove the damper housing, spring, pad, and shims from above the pinion housing.

Unscrew the secondary damper housing and remove complete with washer, spring, and damper pad.

Withdraw the pinion tail bearing and shims and the pinion bottom thrust washer, placing a container to catch any oil that may drain from the steering rack. The top thrust washer will remain trapped behind the steering rack.

Unlock the tie-rod ball-end locknuts and remove the ball-end assemblies. Release the rubber gaiter seal clips and remove the seals.

Secure the rack housing between suitable clamps in a vice and tap back the washers locking the tie-rod ball housings. Unscrew the ball housings and remove the lock washers.

# J

## THE STEERING GEAR

### Section J.8

#### REASSEMBLING THE STEERING GEAR

Insert the ball end of the tie-rod in the female housing and assemble the ball seat, male seat housing, and shims. Tighten the two housings together with special tools 18G312 and 18G313. The ball must be a reasonably tight sliding fit without play. Adjustment is carried out by varying the thickness of the shims between the ball housings. The shims are provided in thicknesses of .003 and .005 in. (.08 and .13 mm.). When correctly adjusted fit a new lock washer to one end of the steering rack, then replace and tighten the ball housing with special tool 18G313. The ball housing must be locked in three places by the flange of the lock washer.

Insert the top thrust washer (the thick one) with the slotted side away from the pinion and insert the rack in its housing. Refit and adjust the other ball seat.

Refit the rubber gaiters and clips.

Replace the ball-end locknuts and joint assemblies in their approximate original positions.

Fit a new pinion shaft felt seal.

If the chassis frame front extension is in position, the steering rack assembly should be positioned on its mounting brackets by reversing the procedure detailed in Section J.6 before refitting the pinion.

Replace the smaller thrust washer on the plain end of the pinion shaft.

Replace the shims and the pinion tail bearing and secure them in position. Check the end-play of the pinion shaft, which should be between .002 and .005 in. (.05 and .13 mm.). If necessary, the shims must be adjusted to give this degree of play.

To adjust the rack damper the plunger must be replaced in the cap and the cap screwed into position without the spring or shims until it is just possible to rotate the pinion shaft by drawing the rack through its housing. A feeler gauge is then used to measure the clearance between the hexagon of the plunger cap and its seating on the rack housing. To this figure must be added an additional clearance of .002 to .005 in. (.05 to .13 mm.) to arrive at the correct thickness of shims which must be placed beneath the damper cap. The shims are .003 in. (.08 mm.) thick.

Remove the damper cap and plunger and replace and tighten the assembly with the requisite number of .003 in. (.08 mm.) shims as defined in the previous paragraph.

Replace the secondary damper without shims.

Pump approximately  $\frac{1}{2}$  pint (.28 litre) of Hypoid oil to Ref. B (page P.7) into the rack housing through the nipple provided, or release one of the outer rubber gaiter clips and pour the oil in through a funnel. Move the rack assembly backwards and forwards slowly to distribute the oil.

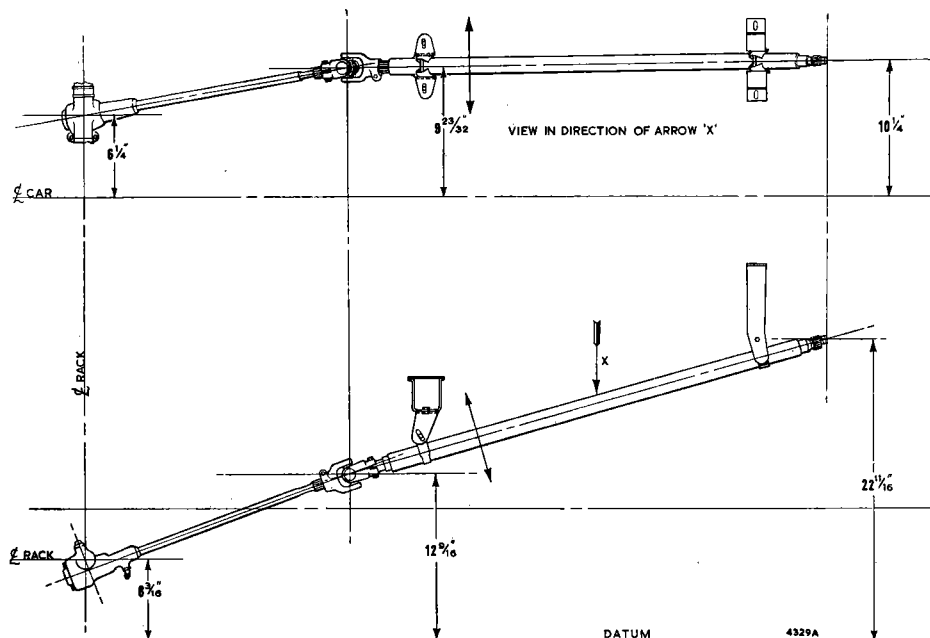

Fig. J.2

Steering column alignment

## Section J.9

### STEERING COLUMN ALIGNMENT

When assembling the steering column or steering gearbox assembly to the car care must be taken to ensure a free condition at the universal joint before the column or gearbox securing bolts are tightened. For the universal joint to be completely unloaded the centre-line of the steering column and the centre-line of the steering rack pinion must pass through the centre of the universal joint spider when the assembly is viewed from above and from the side. Failure to ensure complete freedom at the universal joint will load the steering pinion upper bearing and cause extreme wear and steering stiffness.

To enable the assembly to be secured in the correct position the attachment holes in the support bracket at the lower end of the steering column are slotted to permit up and down and sideways movement, and packing shims (see Fig. J.3) are fitted between the steering gearbox mounting bosses and the brackets on the front suspension member.

Tighten the universal joint clamp bolts.

With the steering column draught-excluding rubber clamp plate and all column and rack securing bolts slack, position the universal joint and tighten the support bracket clamp bolts at the lower end of the column.

Should there be a gap between the gearbox bosses and mounting brackets, remove the bolts, pack with shims as required, and replace and tighten the securing bolts.

To ensure complete alignment again slacken and retighten the steering column lower support bolt.

Tighten the upper support bracket bolt.

## Section J.10

### CHECKING AND ADJUSTING FRONT WHEEL ALIGNMENT

When checking the track width at the front and the rear of the front wheels use a suitable trammel or any special proprietary alignment gauge available.

The wheels should run parallel and have no toe-in.

See that the tyres are inflated to the correct pressures.

Set the wheels in the straight-ahead position.

Set the arms of a suitable trammel to the height of the hub centre on the outside of the wheels.

Place the trammel to the rear of the wheels and adjust the pointers to register with the wheel rims. Chalk the position of the pointers in each wheel rim and push the car forward one half-turn of the wheels. Take the front reading from the same marks on the rims. For the

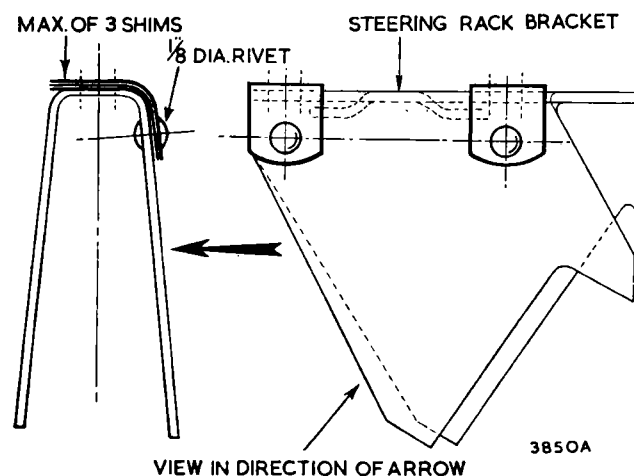

Fig. J.3

*The location of the steering gearbox mounting bracket shims which are used to position the gearbox and assist in obtaining correct steering column alignment. When the necessary thickness of shims has been determined they are riveted to the chassis frame to prevent their loss*

alignment to be correct the pointers should again register with the marks on the rims.

If adjustment is necessary, proceed as follows.

Slacken the locknuts at the ends of the short tie-rods and the clips securing the rubber gaiters to the tie-rods.

Use the spanner flats on the rods to rotate each of the tie-rods **equally** in the desired direction. These both have right-hand threads.

**NOTE.**—To ensure that the steering gearbox is in the central position and that the steering geometry is correct it is important that the tie-rods are adjusted to exactly equal lengths. This can be ascertained by measuring from the end of the flats to the locknuts.

After adjustment retighten the ball joint locknuts and rubber gaiter clips and ensure that the machined under sides of the ball joints are in the same plane.

## Section J.11

### FITTING AN ADJUSTABLE STEERING COLUMN

Remove the steering wheel as detailed in Section J.1.

Remove the steering column assembly as detailed in Section J.2.

Fit the steering column to the car and tighten the clamp bolts.

Fit the steering wheel, locating it on the splines to bring the centre-line of the spokes horizontal when the road wheels are in the straight-ahead position.

# J

## THE STEERING GEAR

---

### SPECIAL TOOLS

#### 18G310. Steering Wheel Remover

This extractor has been specially designed to remove the steering wheel without damage.

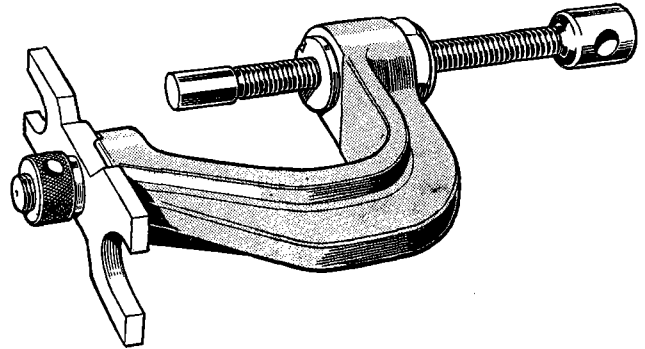

18G310

#### 18G312. Steering Tie-rod Pin Spanner

This tool is designed for use with the special C-spanner 18G313 for dismantling the steering tie-rod ball housing. In use it is clamped in a vice and the pins of the spanner are engaged with the holes in the housing. Use the spanner 18G313 to unscrew the housing cap.

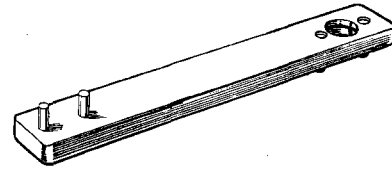

18G312

#### 18G313. Steering Tie-rod C-Spanner

Designed to engage the shallow splines of the steering rack ball housing cap and remove it without damage.

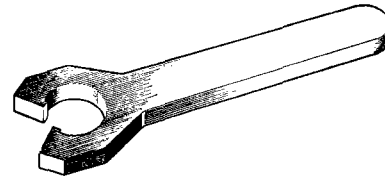

18G313